





Motorized display solutions 2019





Motorized line-up 2019



Motorized mounting solutions have become an important pillar within the professional AV market. For this reason, Vogel's PROF is expanding its range of Motorized products.

The modularity of the new line-up is unique. With only a few components you can create almost every solution.

Features:

- Ample storage space
- Connect-it accessories compatible
- Different travel lengths and lift weights available
- Multi-voltage control box

The new line-up will make the PFFE 7131 redundant.

Motorized display solutions: new motorized display lifts

PFFE 7105

Motorized display lift 50 cm



- Max. weight:
200 kg – floor mounted double pole
150 kg – floor mounted
120 kg – trolley / floor stand
- Travel: 50 cm
- Min. height column: 647 mm

PFFE 7106

Motorized display lift 60 cm



- Max. weight:
200 kg – floor mounted double pole
150 kg – floor mounted
120 kg – trolley / floor stand
- Travel: 60 cm
- Min. height column: 912 mm

PFFE 7109

Motorized display lift 99 cm

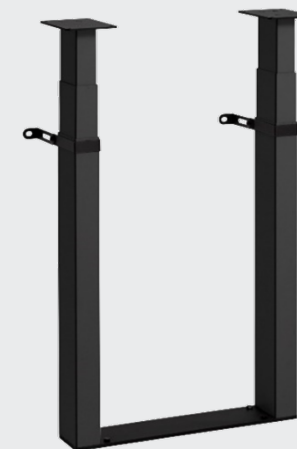

- Max. weight:
120 kg – floor mounted
- Travel: 99 cm
- Min. height column: 704 mm
- Comes with floor mounting plate and wall brackets

Motorized display solutions: new interface box

PFI 3061

Interface box for PFFE 7105/06

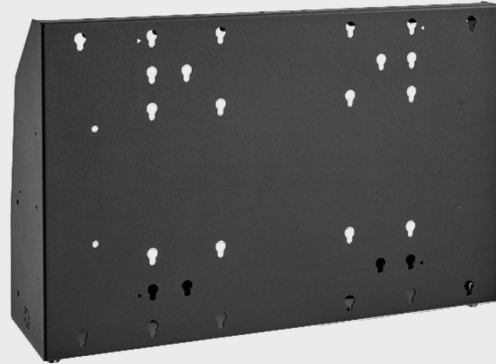

- VESA max.: 600x400
- Ample storage space
- Compatible with Connect-it accessories
- Designed for:
 - PFFE 7105
 - PFFE 7106

PFI 3062

Interface box for PFFE 7109

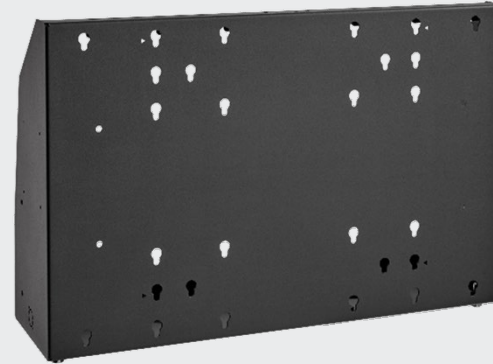

- VESA max.: 600x400
- Ample storage space
- Compatible with Connect-it accessories
- Designed for:
 - PFFE 7109

Motorized display solutions: new accessories

PFA 9146

Fitment extender 800x600



- Extends fitment of PFI 3061 and 3062 to 800x600

PFA 9147

Cover for PFI 3061/3062



- Compatible with PFI 3061 and 3062.
- Cable management
- Lockable

Motorized display solutions: PFI 3061 / 3062



- Ample storage space
- Break-out for Neutrik connectors
- Screen mounting: direct to interface
- Fitment 600x400
- PFI 3061 is designed for PFFE 7105 / 7106
- PFI 3062 is designed for PFFE 7109

Motorized display solutions: PFA 9146 and PFA 9147

PFA 9146 Fitment extender

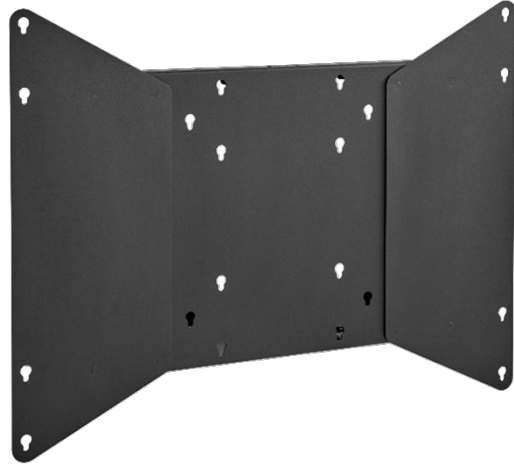

- Extends fitment of PFI 3061 / 3062 to 800x600

PFA 9147 Cover for PFI 3061 / 3062



- Lockable cover for PFI 3061 / 3062
- Slots for ventilation
- Holes for cable management

Motorized display solutions: existing components

PFA 9134

Wall bracket motorized display lift

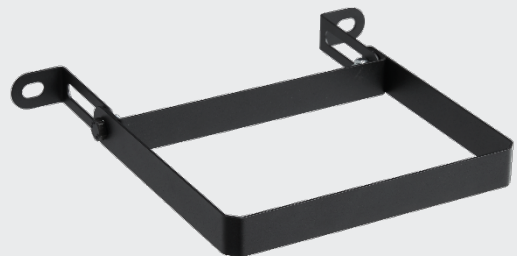

- **Required** to secure the PFFE 7105 / 7106 to the wall when drilled to the floor

PFF 7025

Floor plate large



- Silver & black

PFT 8525

Trolley frame large



- Silver & black

Motorized display solutions overview: Trolley

PFI 3061

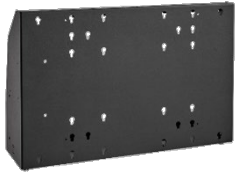

PFFE 7105 or
PFFE 7106



PFT 8525

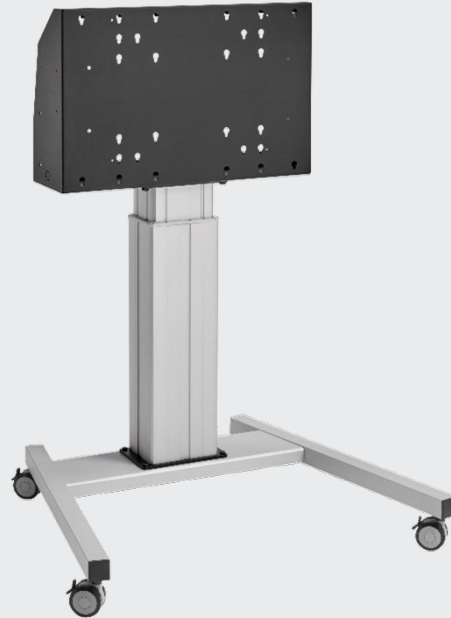

Consists of:

- PFI 3061
- PFFE 7105 or 7106
- PFT 8525



Consists of:

- PFI 3061
- PFFE 7105 or 7106
- PFT 8525

Motorized display solutions overview: Floor stand

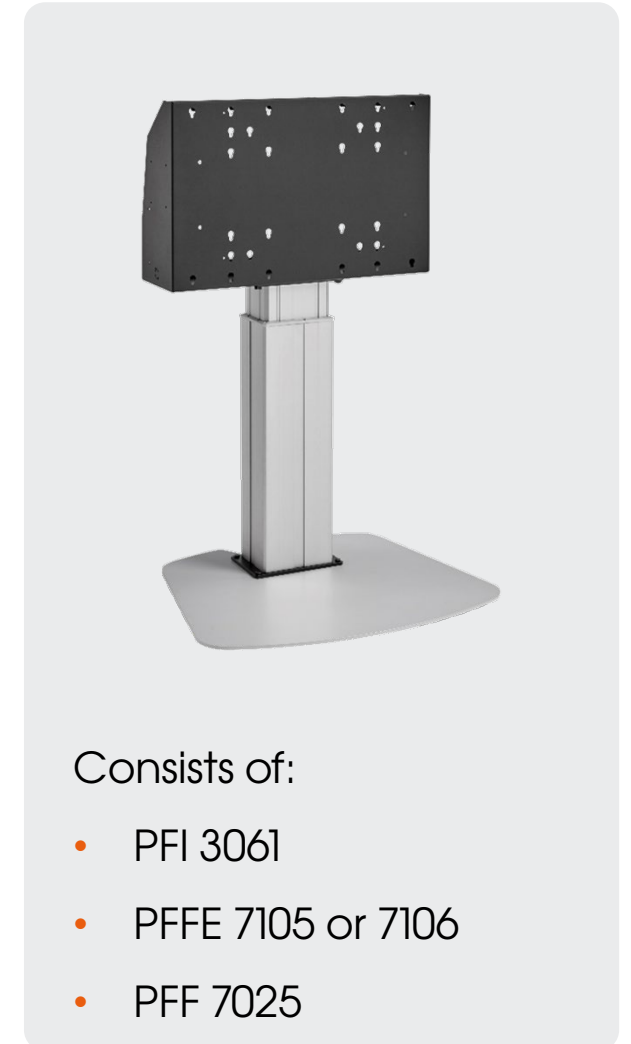
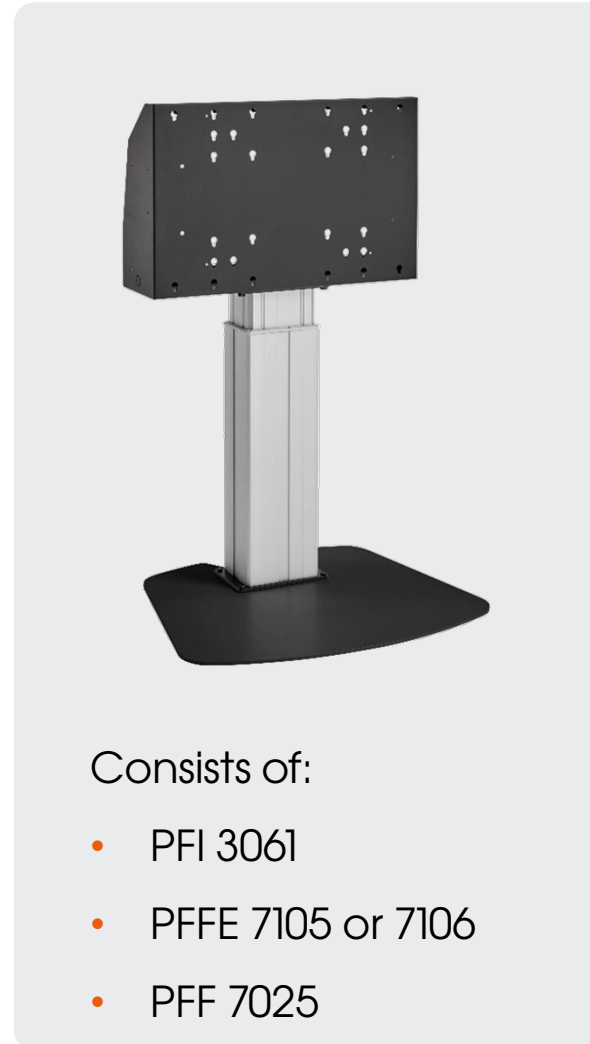
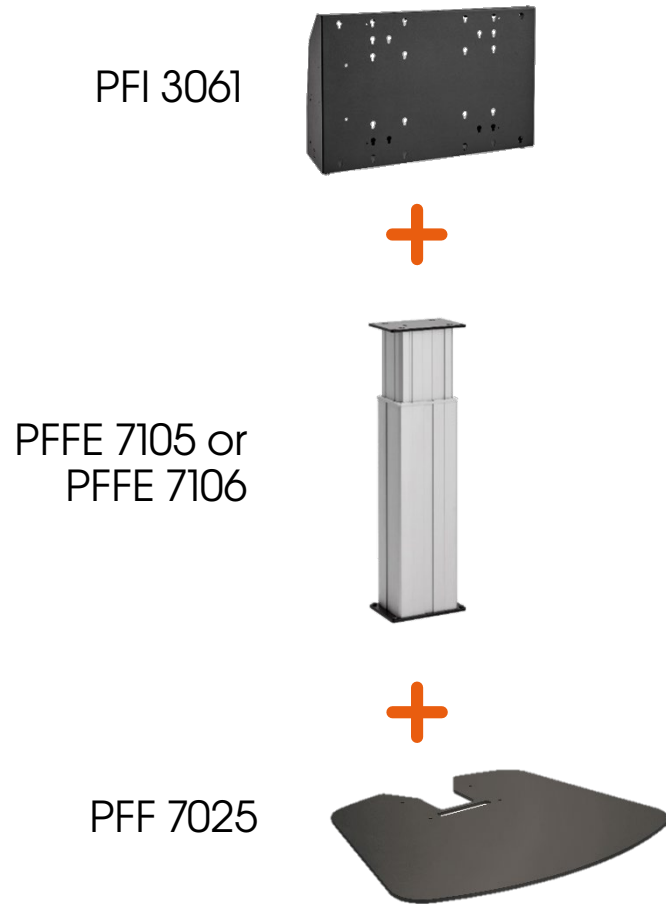

Motorized display solutions overview: Floor mounted



Consists of:

- PFI 3061
- PFFE 7105 or 7106
- PFA 9134



Consists of:

- PFI 3061
- 2x PFFE 7105 or 7106
- 2x PFA 9134

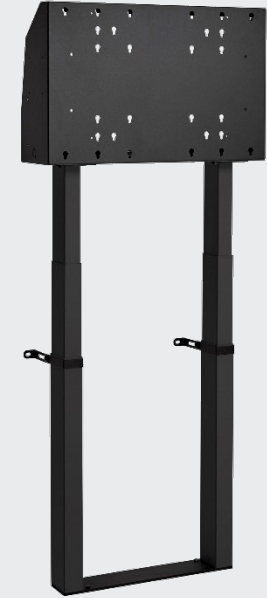

Consists of:

- PFI 3062
- PFFE 7109



Motorized display solutions: Product Data Sheet



Product data sheet PRODUCT DATA SHEET PFI 3061/3062

Dimensions in mm [inch]

PFI 3061 is compatible with PFFE 7105 / 7106
PFI 3062 is compatible with PFFE 7109

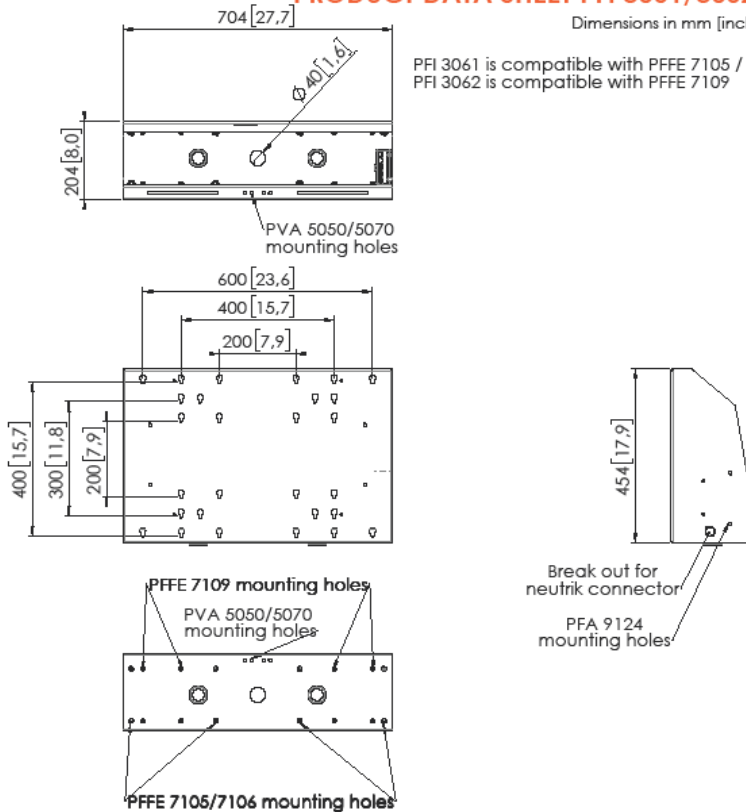

Break out for
neutrik connector

PFA 9124
mounting holes

Note: This document and specifications herein are confidential and the exclusive property of Vogel's Products Inc. Neither the design nor any information contained in this drawing may be reproduced or disclosed to others without written consent of Vogel's Products Inc. The design and information will not be reproduced, copied or used, either in part or in its entirety, as the basis for the manufacture or sale of items without written permission. Warning: Please study all instructions and limitations carefully before installation. Information in this document is subject to change without further notice.

Product Data Sheet PFI 3061, 3062 00
Product data sheet
14-01-19



Product data sheet PFA 9146

Dimensions in mm [inch]

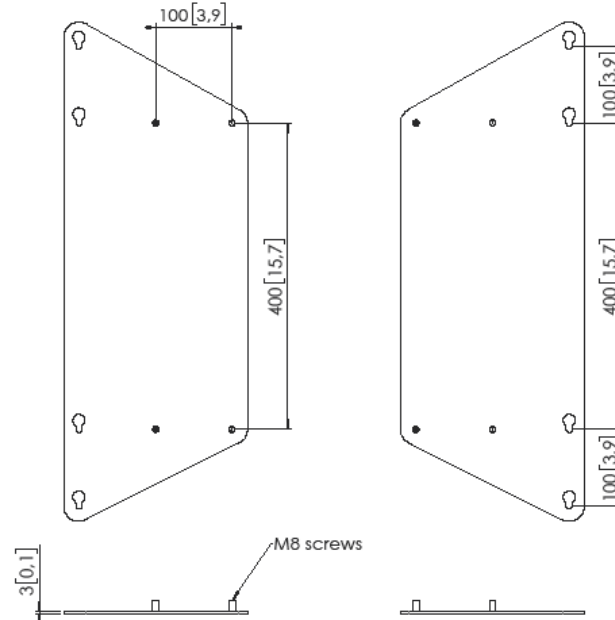

EXTENDS FITMENT OF PFI 3061 / 3062 TO 800x600

Note: This document and specifications herein are confidential and the exclusive property of Vogel's Products Inc. Neither the design nor any information contained in this drawing may be reproduced or disclosed to others without written consent of Vogel's Products Inc. The design and information will not be reproduced, copied or used, either in part or in its entirety, as the basis for the manufacture or sale of items without written permission. Warning: Please study all instructions and limitations carefully before installation. Information in this document is subject to change without further notice.

Product Data Sheet PFA 9146 00
Product data sheet
14-01-19



Product data sheet PFA 9147

Dimensions in mm [inch]

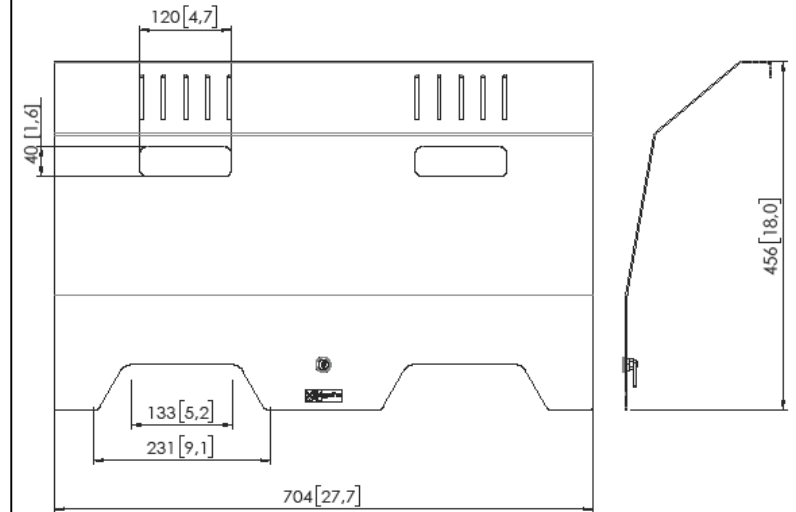

Note: This document and specifications herein are confidential and the exclusive property of Vogel's Products Inc. Neither the design nor any information contained in this drawing may be reproduced or disclosed to others without written consent of Vogel's Products Inc. The design and information will not be reproduced, copied or used, either in part or in its entirety, as the basis for the manufacture or sale of items without written permission. Warning: Please study all instructions and limitations carefully before installation. Information in this document is subject to change without further notice.

Product Data Sheet PFA 9147 00
Product data sheet
14-01-19



Motorized display solutions: Product Data Sheet



Product data sheet PFFE 7105

Dimensions in mm [inch]

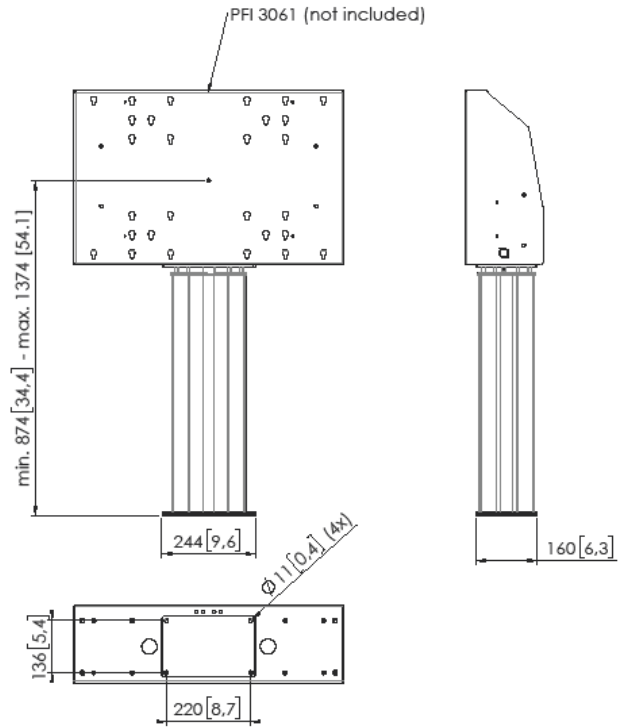

Note: This document and specifications herein are confidential and the exclusive property of Vogel's Products Inc. Neither the design nor any information contained herein may be reproduced or disclosed to others without written consent of Vogel's Products Inc. The design and information will not be reproduced, copied or used, either in part or in its entirety, as the basis for the manufacture or sale of items without written permission. Warning: Please study all instructions and limitations carefully before installation. Information in this document is subject to change without further notice.

Product Data Sheet PFFE 7105-00
Product Data Sheet
14-01-19



Product data sheet PFFE 7106

Dimensions in mm [inch]

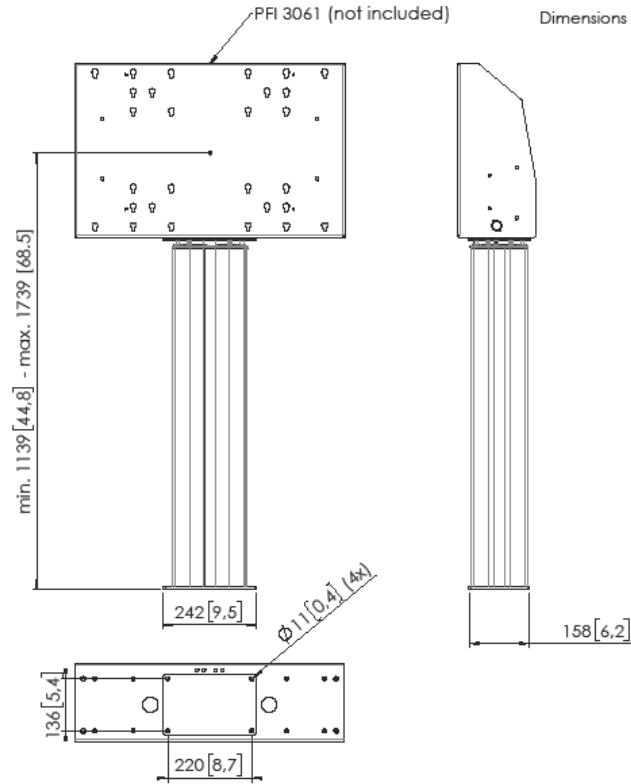

Note: This document and specifications herein are confidential and the exclusive property of Vogel's Products Inc. Neither the design nor any information contained herein may be reproduced or disclosed to others without written consent of Vogel's Products Inc. The design and information will not be reproduced, copied or used, either in part or in its entirety, as the basis for the manufacture or sale of items without written permission. Warning: Please study all instructions and limitations carefully before installation. Information in this document is subject to change without further notice.

Product Data Sheet PFFE 7106-00
Product Data Sheet
14-01-19



Product data sheet PFFE 7109

Dimensions in mm [inch]

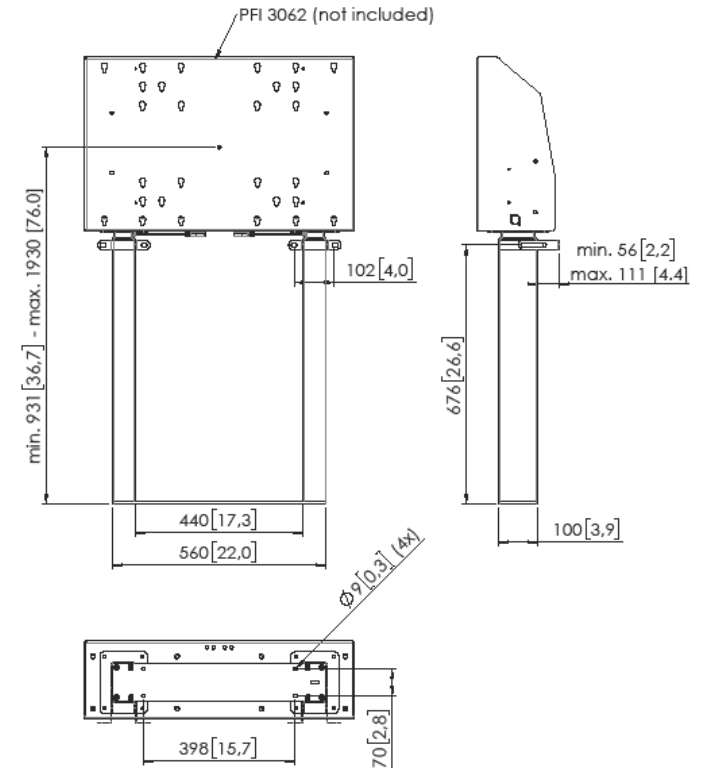

Note: This document and specifications herein are confidential and the exclusive property of Vogel's Products Inc. Neither the design nor any information contained herein may be reproduced or disclosed to others without written consent of Vogel's Products Inc. The design and information will not be reproduced, copied or used, either in part or in its entirety, as the basis for the manufacture or sale of items without written permission. Warning: Please study all instructions and limitations carefully before installation. Information in this document is subject to change without further notice.

Product Data Sheet PFFE 7109-00
Product Data Sheet
14-01-19



Motorized display solutions: Logistical information

NEW

Model nr.	Description	Item Nr	Color	On pallet (pcs)	Carton Dimensions wxlxh (mm)	Weight box (kg)	Weight box (lbs)	EAN-13
PFFE 7105	PFFE 7105 Motorized display lift 50 cm	7371054	Silver	8	801x287x226	16,5	36.38	8712285342981
PFFE 7106	PFFE 7106 Motorized display lift 60 cm	7371064	Silver	8	1094x295x238	21,5	47.40	8712285343001
PFFE 7109	PFFE 7109 Motorized display lift 99 cm	7371090	Black	8	934x174x173	21,5	47.40	8712285342905
PFI 3061	PFI 3061 Interface box for PFFE 7105 / 7106	7230610	Black	8	764x478x264	13,4	29.54	8712285343308
PFI 3062	PFI 3062 Interface box for PFFE 7109	7230620	Black	8	764x478x264	13,4	29.54	8712285343322
PFA 9146	PFA 9146 Interface extender 800x400	7291460	Black	80	679x269x88	0,75	1.65	8712285343346
PFA 9147	PFA 9147 Cover for PFI 3061/3062	7291470	Black	20	764x534x168	6,5	14.33	8712285343360

CURRENT

Model nr.	Description	Item Nr	Color	On pallet (pcs)	Carton Dimensions wxlxh (mm)	Weight box (kg)	Weight box (lbs)	EAN-13
PFF 7025	PFF 7025 Floor plate large black	7370250	Black	18	600x800x50	25,5	56.2	8712285337208
PFF 7025	PFF 7025 Floor plate large silver	7370254	Silver	18	600x800x50	25,5	56.2	8712285337222
PFA 9134	PFA 9134 Wall bracket	7391340	Black	96	200x200x50	0,5	1.1	8712285337246
PFT 8525	PFT 8525 Trolley frame large black	7385250	Black	7	1057x884x214	15,8	34.38	8712285337260
PFT 8525	PFT 8525 Trolley frame large silver	7385254	Silver	7	1057x884x214	15,8	34.38	8712285337284

